

MODEL “CG3-BDL-DS-MA”

WATER-WASH VENTILATOR

GENERAL SPECIFICATIONS

Furnish Gaylord Ventilator Model “CG3-BDL-DS-MA_____” as shown on plans and in accordance with the following specifications:

GENERAL: Each ventilator shall have one high-velocity centrifugal grease extractor with two air inlet slots, one on each side of the extractor. One slot shall have an adjustable baffle to regulate the ratio of exhaust volume between the two slots. Each ventilator shall utilize three full-length horizontal self draining baffles for centrifugal grease extraction providing a grease extraction rate of up to 95% of the mechanically extractable particulate when operated at design specifications. The use of filters, cartridges or constant running water to extract grease is not acceptable. The baffle at the air inlet shall be a three position damper controlled by an electrically driven actuator. In position number one, the fan on mode, the damper shall be a grease extracting baffle, position two the damper shall be in the wash mode and position number three in the fire mode. The main grease gutter shall have a 1" slope to the drain opening and the drain shall be equipped with a pre-flush line to purge the drain during a wash cycle. Continuous brackets shall be provided to facilitate hanging from the overhead structure. (Optional) The ventilator shall include “Custom Air” baffles to reduce the exhaust air volume over specific cooking equipment as indicated on the plans (add suffix “CA” to model number). The ventilator shall operate at air quantities as shown on plans.

AUTOMATIC WASHDOWN SYSTEM: The ventilator shall include a full length wash manifold equipped with two rows of brass spray nozzles. When the wash cycle is initiated the exhaust fan is shut off, the damper shall close forward to seal off the air inlet slot exposing the entire grease gutter to the wash sprays. At the conclusion of the wash cycle the damper shall remain closed, in the “System Off” position, preventing conditioned air from escaping the occupied space via thermal drafts, and then re-open when the exhaust fan is started. All controls and components for operation of the wash system shall be housed in the Ventilator Control Cabinet.

INTERNAL FIRE PROTECTION: The ventilator shall be equipped with an internal fire protection system activated by thermostat(s) located at the duct collar. When the temperature of the exhaust air reaches the set point, the fire damper shall automatically close in the direction of the exhaust air flow, sealing against the back wall of the ventilator, and act as a barrier to prevent flame from entering the extraction chamber and duct system. The exhaust and make up air fans shall shut off, and the internal wash system shall be initiated, acting as a deterrent to fire in the plenum and exhaust ductwork. In addition, the internal water sprays shall continuously bathe the fire damper to eliminate warping of the damper during a severe fire condition. The water sprays shall remain on until the thermostat temperature drops below its set point, then stay on for a two minute cool down cycle. During the cool down cycle the damper shall open and upon completion the water sprays shall shut off and the exhaust fan re-start. (Optional) A remote fire switch shall be provided and shall be located at an exit. Pulling the fire switch shall turn on the water sprays, open the fire damper to the fan on position and turn on the exhaust fan.

MAKE-UP AIR OPTIONS: The ventilator shall have an air supply plenum, with duct collar(s) and:

Incorporate registers for front face discharge make-up air. (Add suffix “MAR” to the model number.)

Incorporate removable stainless steel perforated panels for front face discharge make-up air. (Add suffix “MAW” to the model number.)

(Optional Fuse Link Fire Dampers) Provide fuse link activated fire damper located at the duct collar. *Specifier note: This arrangement eliminates the three position inlet damper and is replaced by a fixed baffle. This option is identified by the model number prefix CG3-FDD.*

(Optional No Fire Damper) This option is identified by the model number prefix CG3-ND.

ACCESSIBILITY AND INSPECTION: The ventilator shall be equipped with full-length non-gasketed hinged inspection doors so that service can be performed on fire suppression system nozzles, fusible links, wash system manifolds and nozzles, drains and other interior components without removing any panels, dampers or baffles. No tools shall be required to access the interior of the extraction chamber or plenum.

CONSTRUCTION: The ventilator shall be of all stainless steel construction, not less than 18 gauge, type 300 series. All exposed surfaces shall be a number 4 finish. The use of aluminized steel, galvanized steel, or 430 stainless steel is not acceptable.

ELECTRICAL: The ventilator shall be factory pre-wired to a single connection point. Ventilators built in multiple sections shall be furnished with coiled flex conduit for interconnecting sections by applicable trades.

LIGHT FIXTURES: The ventilator shall be equipped with 100 watt surface mounted incandescent, 150 watt recessed incandescent, recessed fluorescent, light fixtures. Light fixtures shall be factory interwired. Ventilators built in multiple sections shall be furnished with coiled flex conduit for interconnecting sections.

ACCEPTANCE & APPROVALS: The ventilator shall be UL Listed under the category “Exhaust Hood with Exhaust Damper” and listed by NSF. The ventilator shall comply with all requirements of NFPA-96, IMC, UMC, BOCA and SBCCI model codes.

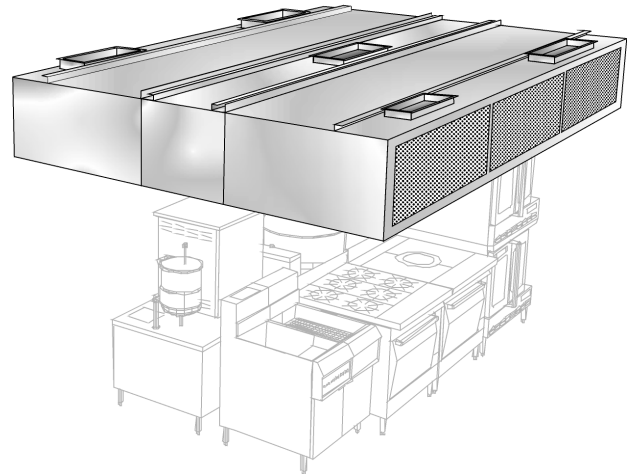

APPLICATION

Used for typical island style cooking arrangements where light and medium duty equipment is used on one side and light-duty equipment is used on the other, and the distance between the equipment does not exceed 30". Consult factory for exceptions. Refer to the Master Engineering Data Sheet in the Engineering Data section of the Gaylord catalog for determining light and medium duty equipment. Includes built-in make-up front face air discharge.

FEATURES

- Three Position, Inlet Slot, Damper
- 95% Grease Extraction Efficiency
- CUL and NSF Listed
- Complies With The IMC, UMC, BOCA and SBCCI Mechanical Codes
- Complies with all Requirements of NFPA-96
- Fail Safe Damper Control Switch

DESCRIPTION

The Gaylord Model “CG3” Series Ventilator has been tested to UL Standard 710 and is UL Listed under the category “Exhaust Hood with Exhaust Damper”. The ventilator extracts up to 95% of the mechanically extractable grease by centrifugal force when operated and maintained in accordance with design specifications. The extracted grease remains out of the airstream until washed away by the hot water, detergent injected wash cycle, which is manually activated by pushing the “Start Wash” button on the control cabinet or automatically activated by the control cabinet if equipped with optional time clock. The 24 hour fire protection is accomplished by the action of the thermostat(s) located at the duct collar. Whenever temperatures reach the set point, the fire cycle is activated which closes the damper at the air inlet of the ventilator, releases fire extinguishing water spray into the interior of the ventilator, and shuts off the exhaust and supply fan.

OPTIONAL EQUIPMENT

1. Decorative Facings and Trim
2. Exhaust Fans, Supply Fans, & Roof Top Units
3. Fire Extinguishing Systems
4. Custom Air (low air volume ventilators)
5. Continuous Cold Water Mist
6. Utility Distribution Systems
7. Pollution Control Systems

GAYLORD INDUSTRIES

10900 SW AVERY ST. • TUALATIN, OREGON 97062 U.S.A.
 PHONE: 800-547-9696 • FAX: 503-692-6048 • email: info@gaylordusa.com
www.gaylordusa.com

MODEL “CG3- -BDL-DS- - ”

DAMPER OPTION MAOPTION DEPTH OF VENTILATOR

** Leave blank = Standard 3 position inlet damper
 FDD = Fuse link damper at the duct collar
 ND = No damper

For supply air option add one of the following suffixes to the model number: MAW MAR
 Add the overall width of the ventilator after the make-up air designation.
 Example: “CG3-BDL-DS-MAW-108”

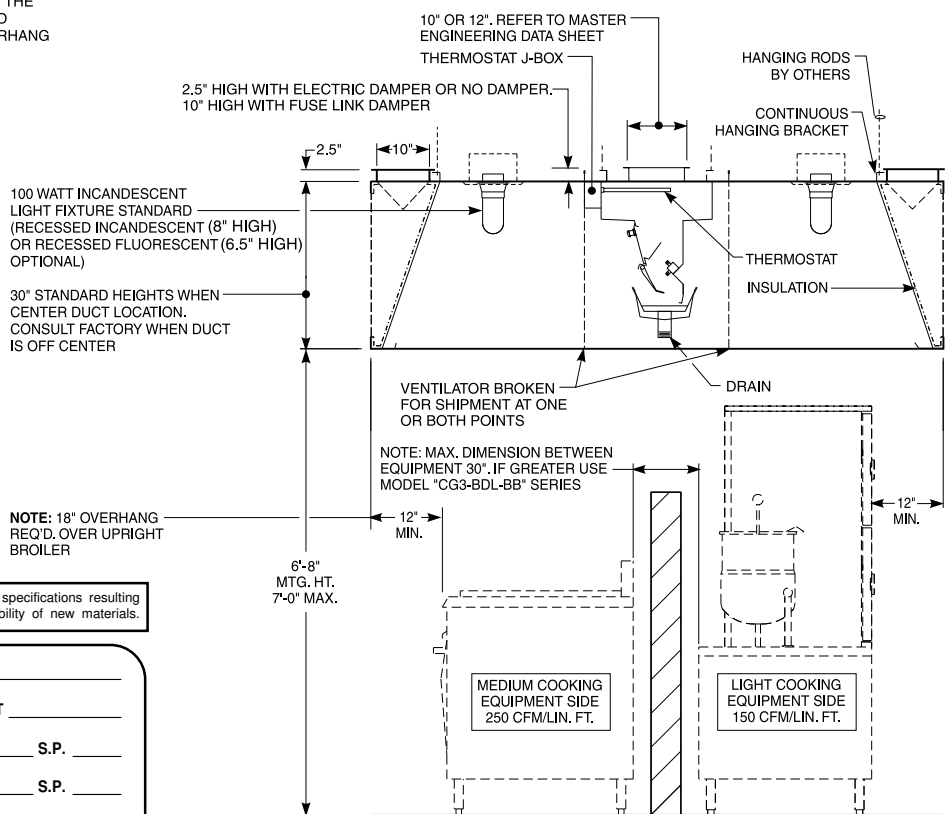
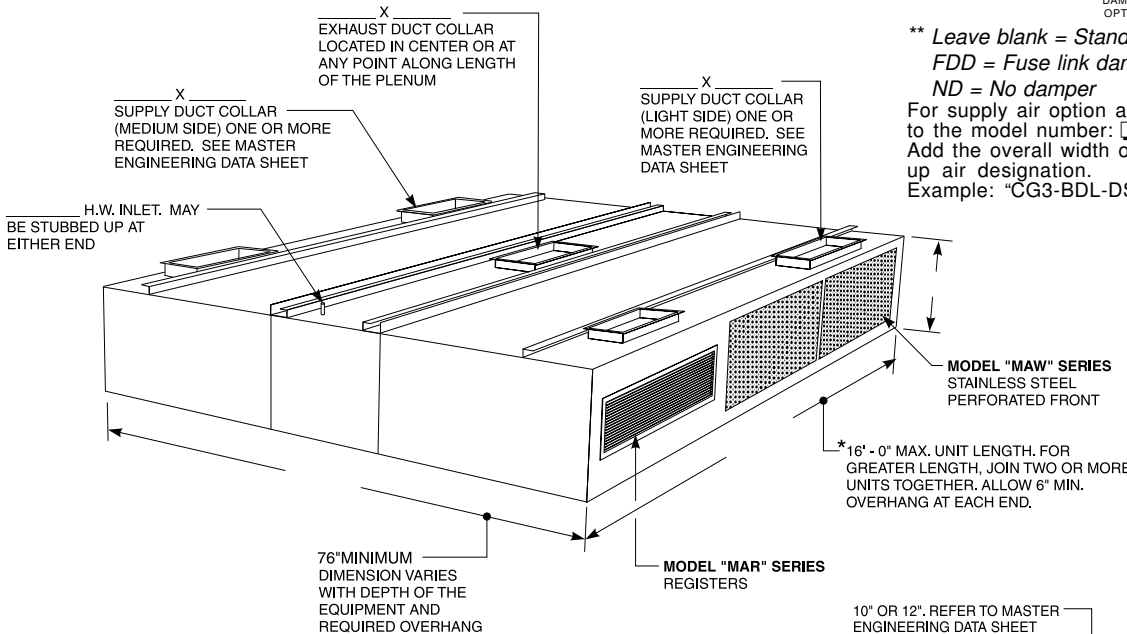

The manufacturer reserves the right to modify the materials and specifications resulting from a continuing program of product improvement or the availability of new materials.

ITEM NO. _____	EST. WT. _____	
LENGTH _____	WIDTH _____	HEIGHT _____
EXHAUST - CFM _____	DUCT SIZE _____	S.P. _____
SUPPLY - CFM (MEDIUM SIDE) _____	DUCT SIZE _____	S.P. _____
SUPPLY - CFM (LIGHT SIDE) _____	DUCT SIZE _____	S.P. _____
H.W. SIZE _____	DRAIN SIZE _____	
_____ GPM @ 40 PSI	WATER TEMP 140° F - 180° F	

Note: All Gaylord Ventilators are provided with a Gaylord Ventilator Control Cabinet. Refer to Control Cabinet specification sheet.

ENGINEERING DATA

Mechanical Requirements

Exhaust volume depends upon the type of cooking equipment and the type and volume of cooking. Refer to the Master Engineering Data Sheet in the Engineering Data section of the Gaylord catalog for the charts to determine exhaust and supply volume, S.P., duct, hot water, and drain sizes. The standard “CG3-BDL-DS-MA” ventilator operates at 250 CFM/lin. ft. on the medium side and 150 CFM/lin. ft. on the light side for a total of 400 CFM/Lin. ft. If the cooking equipment requires more exhaust, as determined by the Master Engineering Data Sheet, it may be necessary to use back-to-back ventilator model “CG3-BDL-BB” series (consult factory).

Electrical

Provide 120 volt 20 amp, 220/240 volt, 50-60 Hz., 24 hour service to Gaylord Ventilator Control Cabinet (refer to Control Cabinet specification sheet). To be fused separately. Lights to be on separate circuit, 120 volt standard, 220/240 volt optional.

Ventilator Lengths

Maximum unit length 16'-0" . For greater lengths, join two or more sections together. Check to ensure that there is adequate access into building and kitchen area.
 Note: Ventilators manufactured outside North America; maximum unit length 10'-0".

***Hanging Weight**

Ventilator Width	8'-6"	9'-0"	9'-6"	10'-0"
Wt. / lineal ft.	Lbs. 165	170	175	180